

High Pressure & Temperature Union Bonnet Valves for Power Plant

GH Series

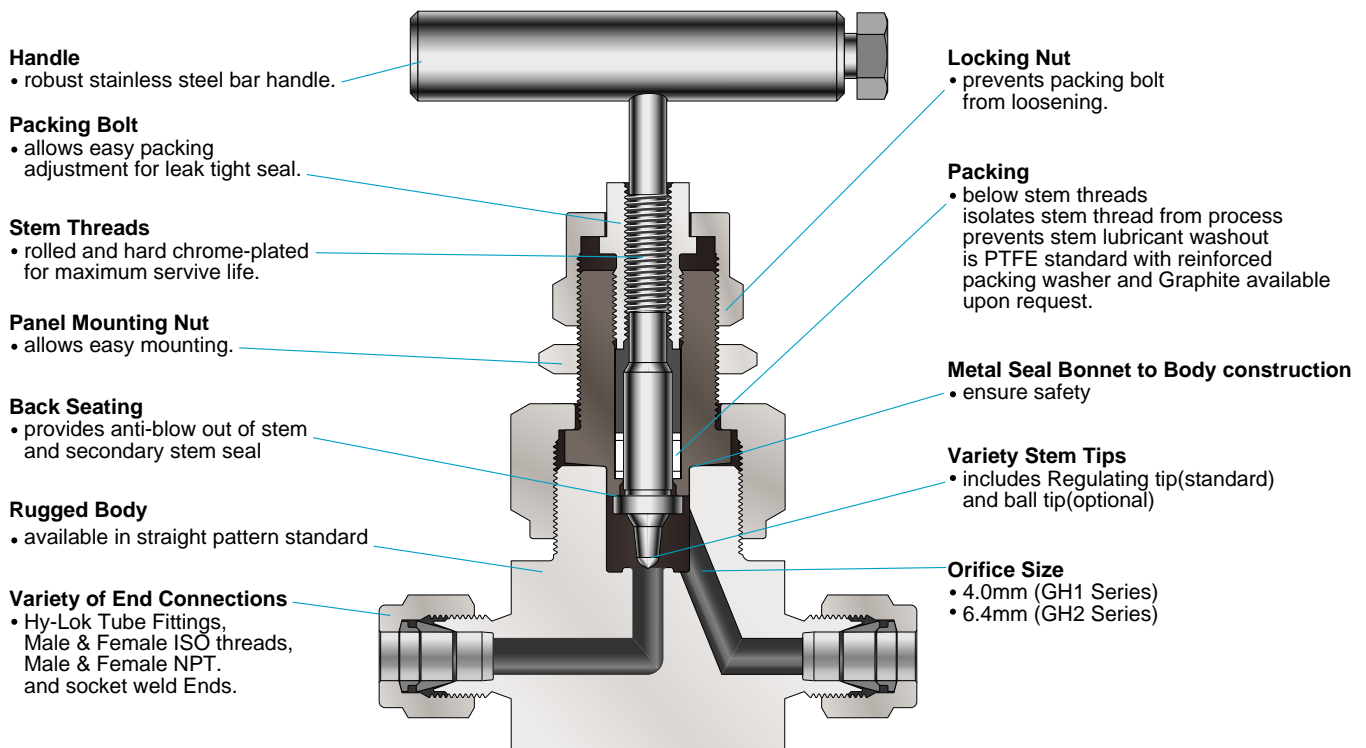

Features

Pressure rating up to **10,000psig(689 bar)** @ 100 °F(38 °C)

Temperature range from -65 °F to 450 °F(-23 °C to 232 °C) with standard PTFE packing and up to 1000 °F (537 °C) with optional Graphite packing.

Body materials available in 316 stainless steel
100% factory tested



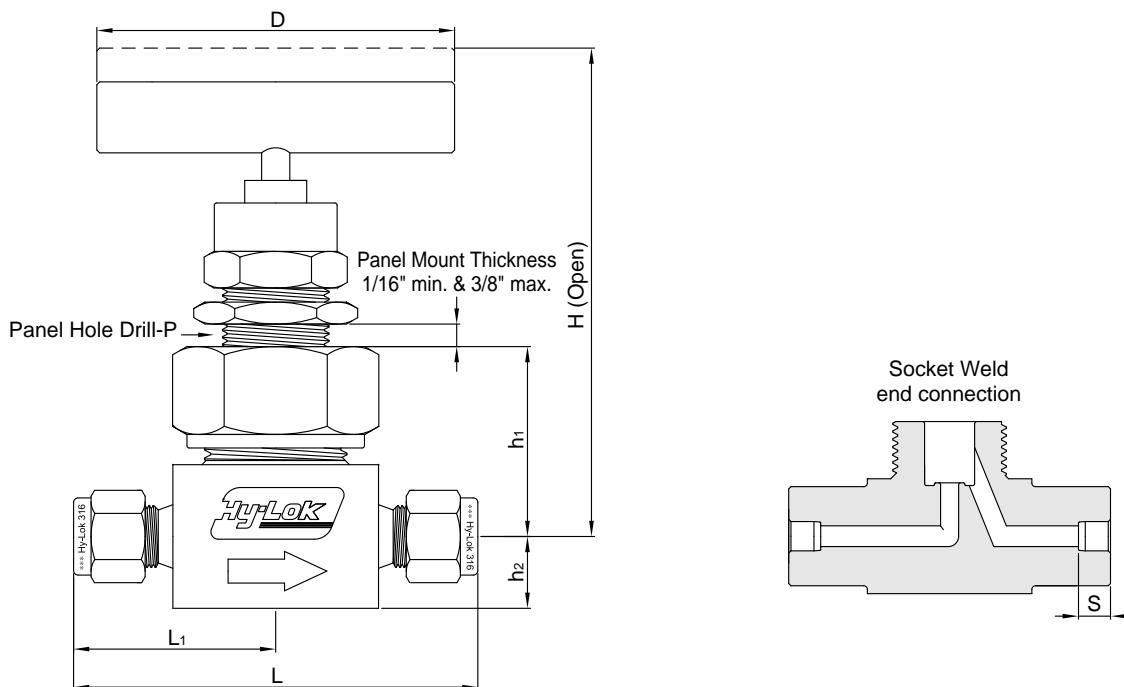
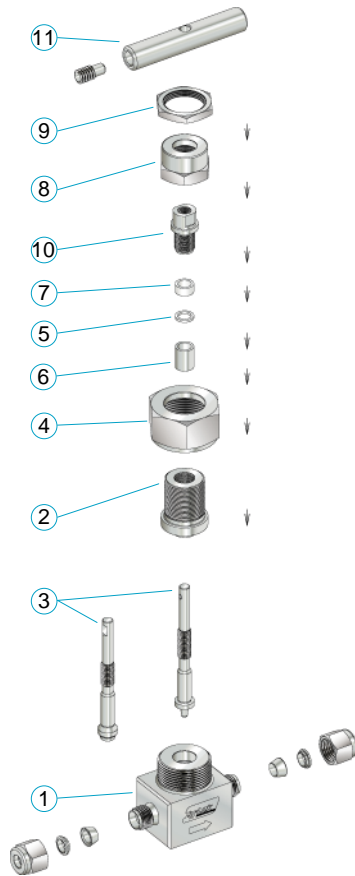

Table of Dimensions

Basic Part NO.		Orifice Hole	Cv Factor	End Connection		Dimensions, mm (in.)											
Series	Part No.			Inlet	Outlet	D	H	h ₁	h ₂	L	L ₁	P	S				
GH1	F	2N	4.0 mm (0.157 in)	0.35	1/8" Female NPT	1/8" Female NPT	63.5 (2.50)	84.1 (3.31)	35.1 (1.38)	12.7 (0.50)	71.4 (2.81)	35.7 (1.40)	20.6 (0.81)	-			
	F	4N			1/4" Female NPT	1/4" Female NPT											
	M	4N			1/4" Male NPT	1/4" Male NPT											
	MF	4N			1/4" Male NPT	1/4" Female NPT					57.2 (2.25)	28.6 (1.13)					
	H	4T			1/4" Hy-Lok	1/4" Hy-Lok											
	SW	4T			1/4" Tube Weld	1/4" Tube Weld									7.1 (0.28)		
GH2	F	4N	6.4 mm (0.252 in)	0.86	1/4" Female NPT	1/4" Female NPT	88.9 (3.50)	105 (4.13)	46.0 (1.81)	16.0 (0.63)	79.5 (3.13)	39.75 (1.56)	26.9 (1.06)	-			
	F	8N			1/2" Male NPT	1/2" Male NPT											
	M	8N			1/2" Female NPT	1/2" Female NPT					108 (4.25)	49.3 (1.94)			19.8 (0.78)	82.6 (3.25)	41.3 (1.63)
	MF	8N			1/2" Male NPT	1/2" Female NPT											

Dimensions in millimeters(inches) are for reference only, subject to change.

Technical Data



Pressure / Temperature Data

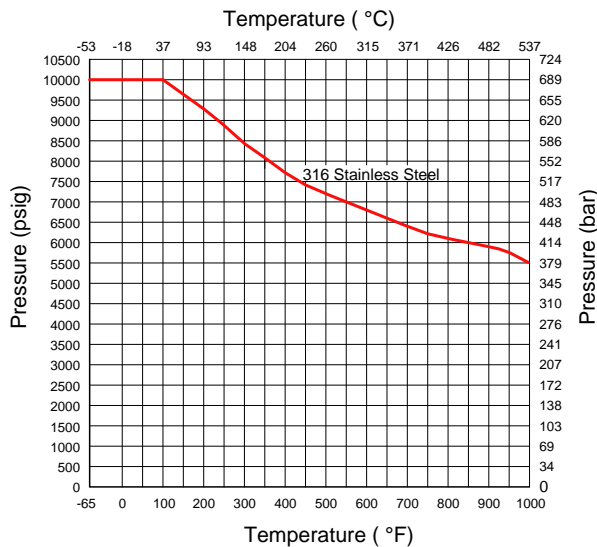

Testing

- Each high pressure bar stock needle valve is tested with nitrogen @ 1000 psig (69 bar) to Max. leak rate of 0.1 SCCM.
- Hydrostatic shell test is performed at 1.5 times the working pressure as an option.
- Other tests are upon request.

Materials of Construction

Description	Grade / ASTM Specification	
	Valve Body Materials	
	SS 316	
1	Body*	316SS / A479
2	Bonnet*	316SS / A479
3	Stem*	316SS / A479
4	Bonnet Nut	316SS / A479
5	Packing*	PTFE
6	Packing Washer*	PTFE (Glass Filled)
7	Packing Gland	SS316 / A479
8	Gland Screw	SS630 / A479
9	Gland Nut	SS316 / A479
10	Lock Nut	SS316 / A479
11	Handle	Stainless Steel

Note : "*" marked are wetted parts.

Pressure-Temperature Ratings

ASME Class	N / A
Material Group	N / A
Material Name	S316
Temperature °F (°C)	Working Pressure psig (bar)
-65 (-53) to 100 (37)	10000 (689)
200 (93)	9290 (640)
250 (121)	8840 (609)
300 (148)	8390 (578)
350 (176)	8045 (554)
400 (204)	7705 (530)
450 (232)	7435 (512)
500 (260)	7165 (493)
600 (315)	6770 (466)
650 (343)	6660 (458)
700 (371)	6480 (446)
750 (398)	6335 (436)
800 (426)	6230 (429)
850 (454)	6085 (419)
900 (482)	5905 (406)
950 (510)	5795 (399)
1000 (537)	5450 (375)

Sour Gas Service

Valves are available in materials which comply with standard NACE MR-01-75 latest revision relating to metallic materials offering optimum resistance to sulfide stress cracking

Flow Coefficient (Cv) vs Number of Handle Turns

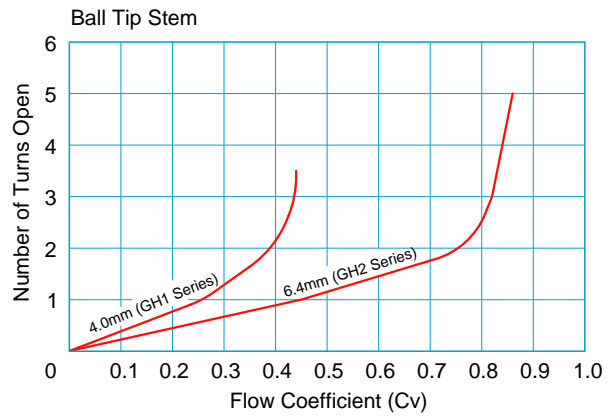
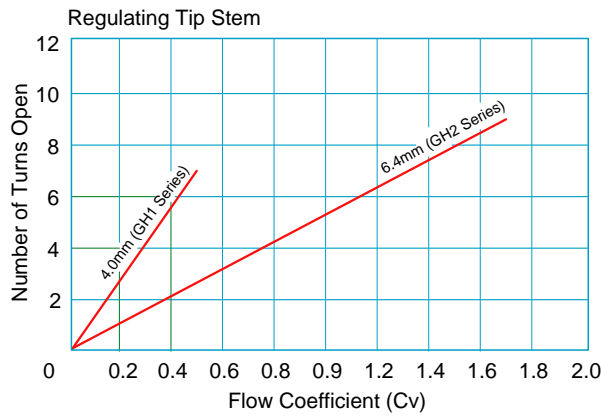

Ordering Information

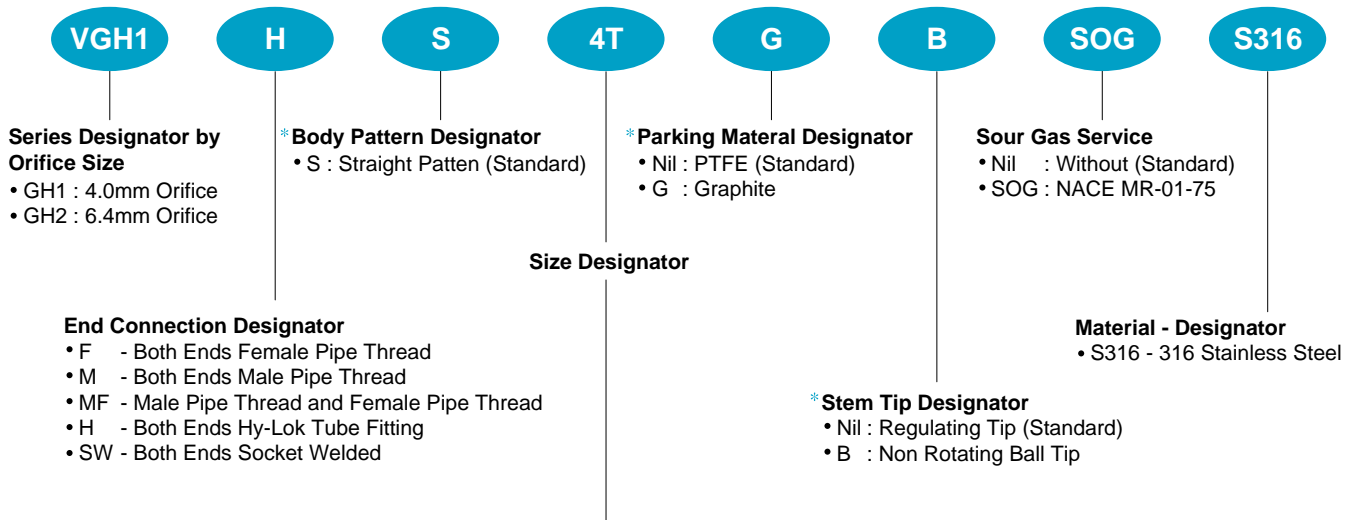

Pipe Thread Designation NPT (ISO / BSP)

Nom. Size	1 / 8	1 / 4	3 / 8	1 / 2	3 / 4	1
Designator	2N(R)	4N(R)	6N(R)	8N(R)	12N(R)	16N(R)

Tube O.D. Designation

Inch Tube	Tube O.D.	1 / 8	1 / 4	3 / 8	1 / 2	3 / 4	1
Designator	2T	4T	6T	8T	12T	16T	
Metric Tube	Tube O.D.	3mm	6mm	10mm	12mm	20mm	25mm
Designator		3M	6M	10M	12M	20M	25M

Note * : No designator is required for standard e.g. GH2MF - 8N - S316.

SAFETY in VALVE SELECTION

Proper installation, material compatibility, operation and maintenance of the valves is the responsibility of the user. The total system design must be taken into consideration to ensure optimal performance and safety.