



INSTRUCTION MANUAL

DOC NO.

IM-BV112S

REV NO.

0

PAGE

1 of 5

112S Series Ball Valve

CONTENTS

1.0 Scope

2.0 Purpose

3.0 Storage, Protection and Handling

4.0 Installation

5.0 Operating

6.0 Maintenance

7.0 Removal

8.0 Attachment

0	2021.09.24	ISSUED FOR APPROVAL	D.H.KIM		Y.H.LEE	K.C.SONG
REV	DATE	DESCRIPTION	PREPARED BY	CHECKED BY	REVIEWED BY	APPROVED BY



INSTRUCTION MANUAL

DOC NO.

IM-BV112S

REV NO.

0

PAGE

2 of 5

1.0 Scope

This manual covers the storage, protection, treatment, installation, operation and maintenance of 112S Series ball valves manufactured by Hy-Lok Corporation.

2.0 Purpose

The purpose of this manual is to maintain the performance of the valves effectively by supplying the user with the storage, protection, installation, correct operation and maintenance method of 112S Series ball valves manufactured by Hy-Lok Corporation.

3.0 Storage, Protection & Handling

3.1 Storage should be off the ground in a clean, dry, indoor area.

3.2 Valves shall be properly protected according to customer's specification and procedure.

3.3 Even in storage site, all valves should be properly packed not to deteriorate the valve during moving and storage.

3.4 Valves should be stored in open position.

3.5 Valves should not be conveyed by grabbing the handle.

3.6 Valves uninstalled for maintenance and each valve components disassembled from valves according to section 7.0 shall be protected from outer impact by packing them separately and shall be stored in clean and dry area.

4.0 Installation

4.1 Preparation

4.1.1 Ensure the specification, pressure range and temperature range, before installing the valves.

4.1.2 The environment of installing valve is suitable to the operator.

4.1.3 To operate the valve, we get the enough space and are free from the potential obstructions to interrupt the operating of the valve.

4.1.4 Piping system shall be cleaned and flushed.

4.1.5 Do not carry the valve with getting the handle.

4.2 Installation

4.2.1 Remove the cap, cover and package.

4.2.2 Inspect valve for transportation damage.

4.2.3 Installation is refer to Doc. No.200TF-OM (Hy-Lok Tube Fitting Operating Manual).

4.2.4 Installation of Pipe or Straight thread follow standard industry practices.

5.0 Operating

▲CAUTION

- Operating of all valves shall be carried out by personnel trained in all aspects of manual.
- Operate the valve after completely install the valve in system.
- Operate the valve in accordance with the specified procedure.
- Do not operate the valve with except handle i.e. spanner, pipewrench etc.

5.1 Operating of Ball valve

5.1.1 Straight Pattern (2-Way)

Quarter-turn the handle to open and close the ball valve.

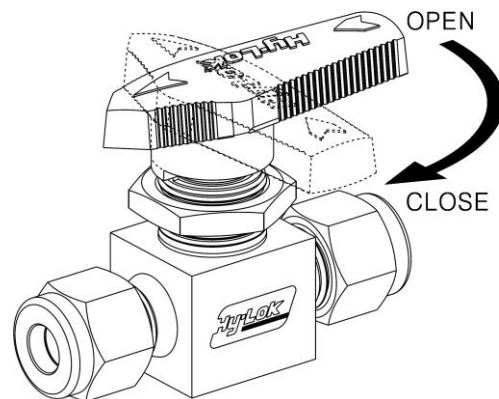

5.1.2 Switching Pattern (3-way)

Half-turn the handle to switch the ball valve.

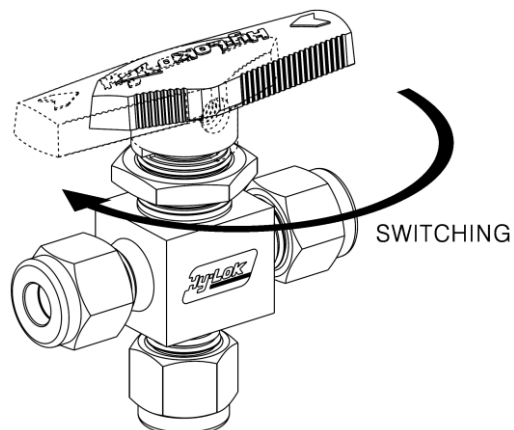

6.0 Maintenance

▲CAUTION

- First of all, the line shall be fully depressurized before attempting any maintenance and if necessary, any dangerous fluids shall be drained.
- The valve being removed should be left in the half open position before removal.
- Before disassembling the valve, ensure the valve has been decontaminated correctly from any harmful gases or fluids and that it is within a safe temperature range for handling.
- Handling of all valves shall be carried out by personnel trained in all aspects of manual.

6.1 Replacement of part components

If no further adjustment of the gland is possible and stem leakage is still evident or seat leakage is suspected, the valve will need to be removed from the line in order for new seats/seals to be fitted.

After removal of the valve, adopt the following procedure to remove, replace and reassemble the part components. (Refer to the attachment)

6.2 Disassembly

6.2.2.1 Loose and remove the Set Screw(8) and remove the Handle(9)

6.2.2.2 Loose and remove the Packing Bolt(6) by using the Hex Spanner.

6.2.2.3 Remove the Disc Spring(5), Packing Gland(4).

6.2.2.4 Remove the Stem(3), Packing(2), Packing Support(10,11).

6.3 Leakage

Stem leakage & In-Line leakage

In case of stem leakage, tighten the Packing Bolt(6). This is accomplished by tightening the packing bolt clockwise in small increments until a leak tight seal is achieved at the stem and across the seat. If the leakage remains after tightening, Loose and remove the Handle(9), Packing Bolt(6) and ensure the damage of Stem(3), Packing(2) and Body(1) inside. If damage, replace the damaged part component(s).

6.4 Reassembly

▲CAUTION

- Before reassemble the valve, there is no damage and corrosion in the inner surface of packing and body. If the damage is a little and not important, polish the part by using the sandpaper and then available to use. If the damage is big and important, replace the part component.
- Turn the handle until bring stem into contact with backseat of bonnet before reassemble Bonnet & stem ass'y in the body

Reassembly order is the reverse of the disassembly.

6.5 Period of Maintenance

6.5.1 Period of the following non-metallic part components is first 2 years of operation.

a) Packing(2)

6.5.2 Metallic components are not normally replaced in the initial 2-year period. Any damage of metallic components such as Stem may necessitate replacement.

7.0 REMOVAL

▲CAUTION

The valve shall be depressurized with the open position before removal. And close the valve after fluids are fully drained.

7.1 Adopt the following procedure to remove.

7.1.1 Get permission to remove the valve.

7.1.2 For preventing the damage of the seat, awfully attention is needed when remove the valve.

7.1.3 After removal, clean the valve and cap the ends with plastic covers.

8.0 Attachment

Attachment – General arrangement drawing(112S Series Ball Valve)

